

(BX) **BRONX**

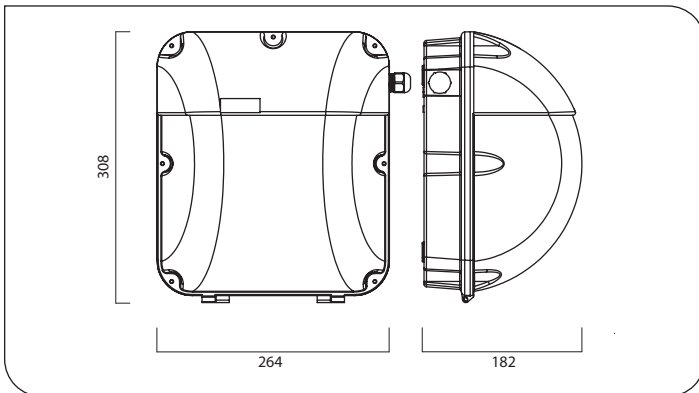

IP65 polycarbonate bulkhead fitting for 70W SON & HQI and 26W & 42W PL lamps.

APPLICATIONS

- Commercial and industrial buildings
- Perimeter lighting
- Pedestrian and vehicular access areas

SPECIFICATION

- 70W SON-EI & HQI-E
- 26W & 42W PL
- Supplied complete with lamps
- 70W SON-EI - unbranded lamp with integral ignitor, colour 220
- 70W HQI - European brand lamp, colour 740
- PL - European brand lamp, colour 840
- PL versions with high frequency control gear

CONSTRUCTION

- Polycarbonate base & eyelid
- Polycarbonate controller

OPTIONS

- **Photo-cell.** Dusk/dawn photo-cell available. Suffix PEC
- **Emergency.** Maintained 3 hours available as listed. Suffix M3.

ORDER CODE	DESCRIPTION
NBX70SON-EI/220	BRONX 70W SON WALL PACK +220 LAMP
NBX70SON-EI/PEC/220	BRONX 70W SON WALL PACK+PE CELL +220 LAMP
NBX70HQI-E/740	BRONX 70W MH WALL PACK +740 LAMP
NBX70HQI-E/PEC/740	BRONX 70W MH WALL PACK+PE CELL +740 LAMP
NBX226/PL/HF/840	BRONX 2X26W PL HF WALLPACK +840 LAMPS
NBX226/PL/HF/M3/840	BRONX2X26W PL HF WALLPACK M3 +840 LAMPS
NBX226/PL/HF/PEC/M3/840	BRONX2X26W PL HF WALLPACK + PE CELL M3 +840 LAMP
NBX226/PL/HF/PEC/840	BRONX 2X26W PL HF WALLPACK + PE CELL +840 LAMPS
NBX142/PL/HF/840	BRONX 1X42W PL HF WALLPACK +840 LAMP
NBX142/PL/HF/PEC/840	BRONX 1X42W PL HF WALLPACK + PE CELL +840 LAMP
NBX142/PL/HF/M3/840	BRONX1X42W PL HF WALLPACK M3 +840 LAMPS
NBX142/PL/HF/PEC/M3/840	BRONX1X42W PL HF WALLPACK + PE CELL M3 +840 LAMP